

High Pressure Piston Regulators

RPGX Series

Introduction

RPGX Series High Pressure Piston Regulators feature a single-stage pressure reduction design with a piston sensing mechanism that is more resistant to damage caused by pressure spikes. These regulators offer a wide outlet pressure range, with a maximum inlet and outlet pressure of up to 10,000 psig. With eight port configuration options, these regulators are ideal for high pressure, low flow applications.

Features

- ⦿ Built-in 40 µm inlet filter for cleanliness and extended service life.
- ⦿ Optional self-venting feature.
- ⦿ Drain port design allows residual liquid media in the downstream pipeline to be vented to a designated location.



Technical Data

Port Size			1/4", 3/8", 6 mm or 8 mm
Max. Working Pressure	316 SS, 316L SS	10000 psig (690 bar)	
	Brass	6000 psig (414 bar)	
Outlet Pressure Range		10 ~ 500 psig (0.69 ~ 34.4 bar)	
		15 ~ 800 psig (1.03 ~ 55.2 bar)	
		15 ~ 1500 psig (1.03 ~ 103 bar)	
		30 ~ 2500 psig (2.1 ~ 172 bar)	
		50 ~ 4000 psig (3.4 ~ 276 bar)	
		60 ~ 6000 psig (4.1 ~ 414 bar)	
		200 ~ 10000 psig (13.8 ~ 690 bar)	
Flow Coefficient (Cv)			0.06
Working Temperature	FKM	-4 ~ 165 °F (-20 ~ 74 °C)	
	NBR	-20 ~ 165 °F (-29 ~ 74 °C)	
SPE (Supply Pressure Effect)	Max. Outlet Pressure: 500, 800 psig	1.1 psig per 100 psig source pressure change	
	Max. Outlet Pressure: 1500, 2500 psig	3 psig per 100 psig source pressure change	
	Max. Outlet Pressure: 4000, 6000 psig	9 psig per 100 psig source pressure change	
	Max. Outlet Pressure: 10000 psig	13 psig per 100 psig source pressure change	
Leak Rate	External	Bubble tight	
	Internal	Bubble tight	

Flow Data

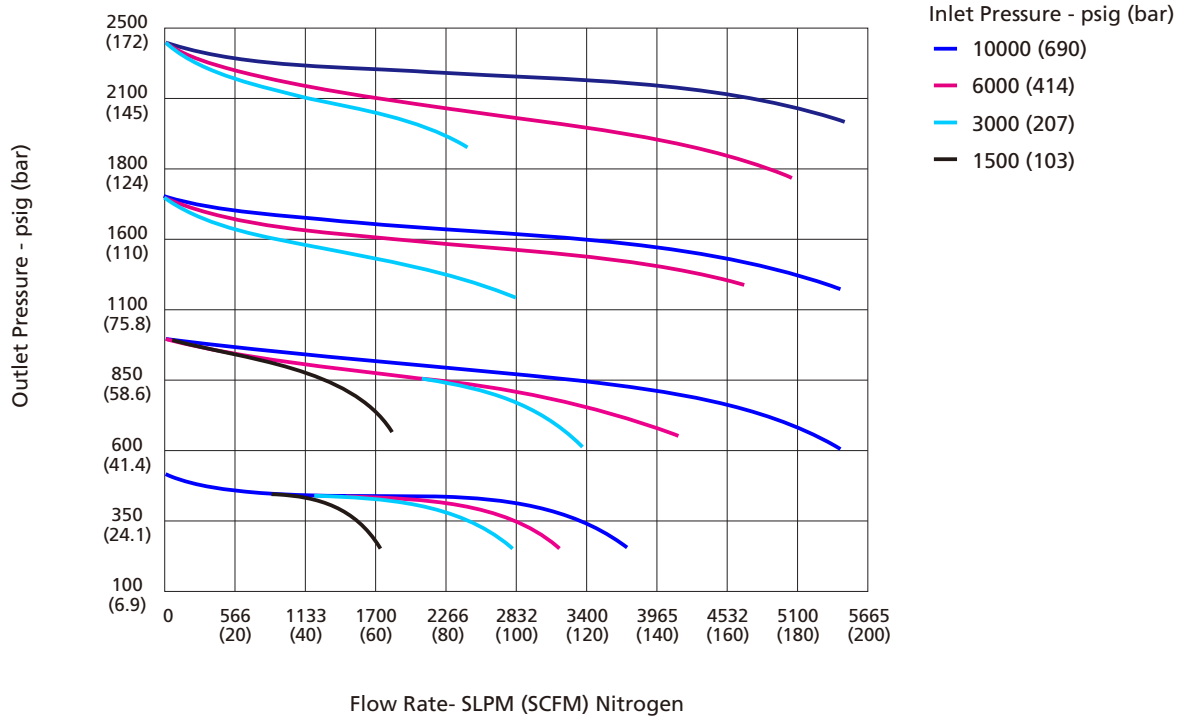

Process Specification

Item	Process Specification	Standard Cleaning and Packaging Process (FC-01)	Special Cleaning and Packaging Process (FC-02)
Material		316 SS, Brass	
Wetted Surface Roughness		Ra 32 μin. (0.8 μm)	
Polishing Process		Machine Finished	
Assembly Environment		At atmosphere	In specially cleaned areas
Packaging		Single bagged	Double bagged

Major Materials of Construction

Gas Control Equipment

Related Products

Technical References

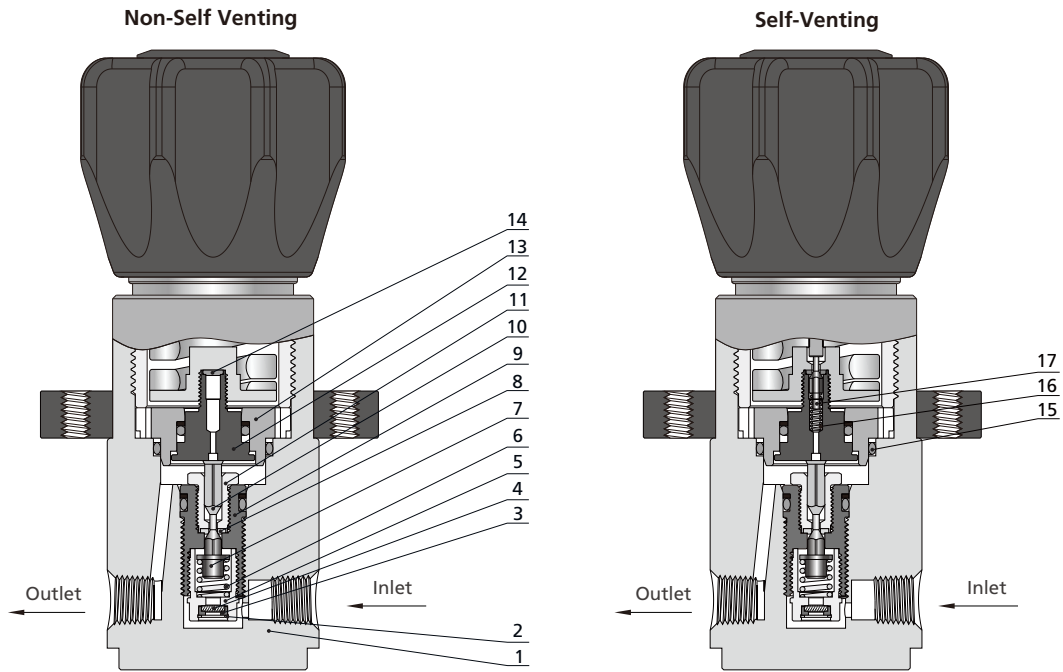

Item	Component	Material/Specification		
		SS	6L	B
1	Body	316 SS	316L SS	Brass
2	Circlips for Bores	Stainless Steel		
3	Retaining Ring	PTFE/ASTM D1710		
4	Filter	316L SS		
5	Main Poppet Cap	316 SS/ASTM A479	316L SS/ASTM A479	316 SS/ASTM A479
6	Poppet Spring	316 SS/ASTM A313		
7	Lift Poppet	N10276/B574		
8	Seat	PEEK		
9	Main Poppet	N10276/B574		
10	Poppet Button	N10276/B574		
11	Seat Retainer	316 SS/ASTM A479	316L SS/ASTM A479	316 SS/ASTM A479
12	Piston	316 SS/ASTM A479	316L SS/ASTM A479	316 SS/ASTM A479
13	Piston Ring	316 SS/ASTM A479	316L SS/ASTM A479	316 SS/ASTM A479
14	Auxiliary Seat	PEEK		
15	O-Ring	FKM or NBR		
16	Poppet Spring	316 SS/ASTM A313		
17	Auxiliary Poppet	N10276/B574		

Porting Configurations

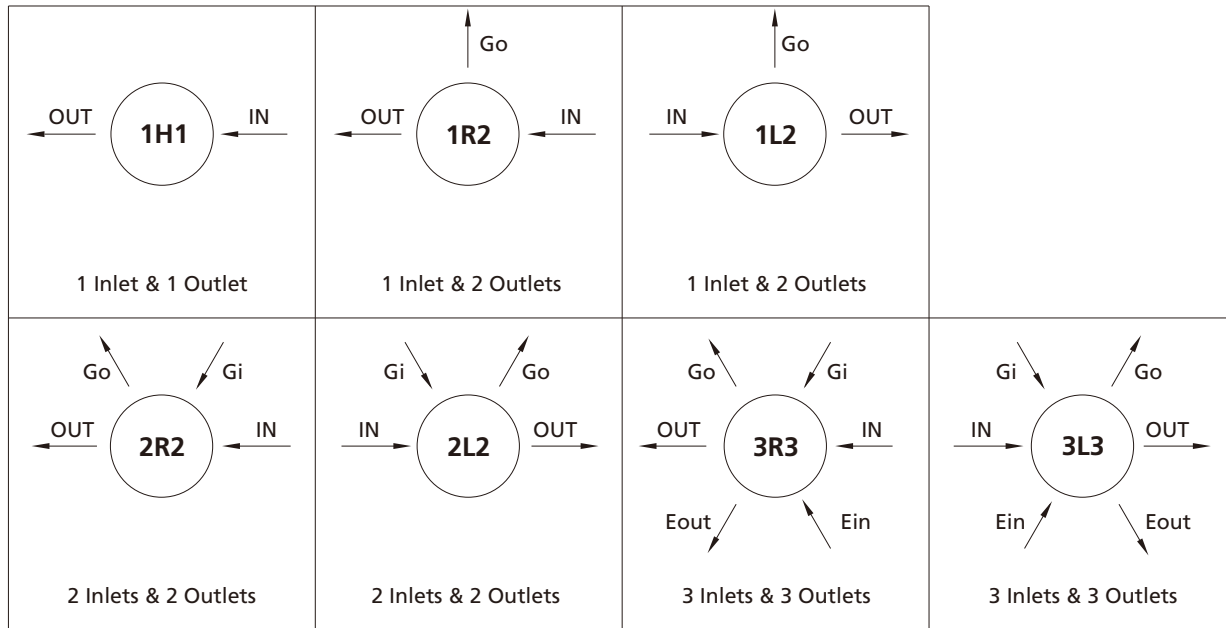

Porting Configuration Symbol

IN	OUT	Gi	Go	Ein	Eout
Inlet	Outlet	Inlet Pressure Gauge Port	Outlet Pressure Gauge Port	Auxiliary Inlet	Auxiliary Outlet

Notes:

1. IN and OUT are the inlet and outlet ports for connecting the valve to the system. Ports other than IN and OUT should not be used for system connections.
2. Porting configuration is viewed from the top.

Dimensions

Dimensions, in inches (millimeters), are for reference only.

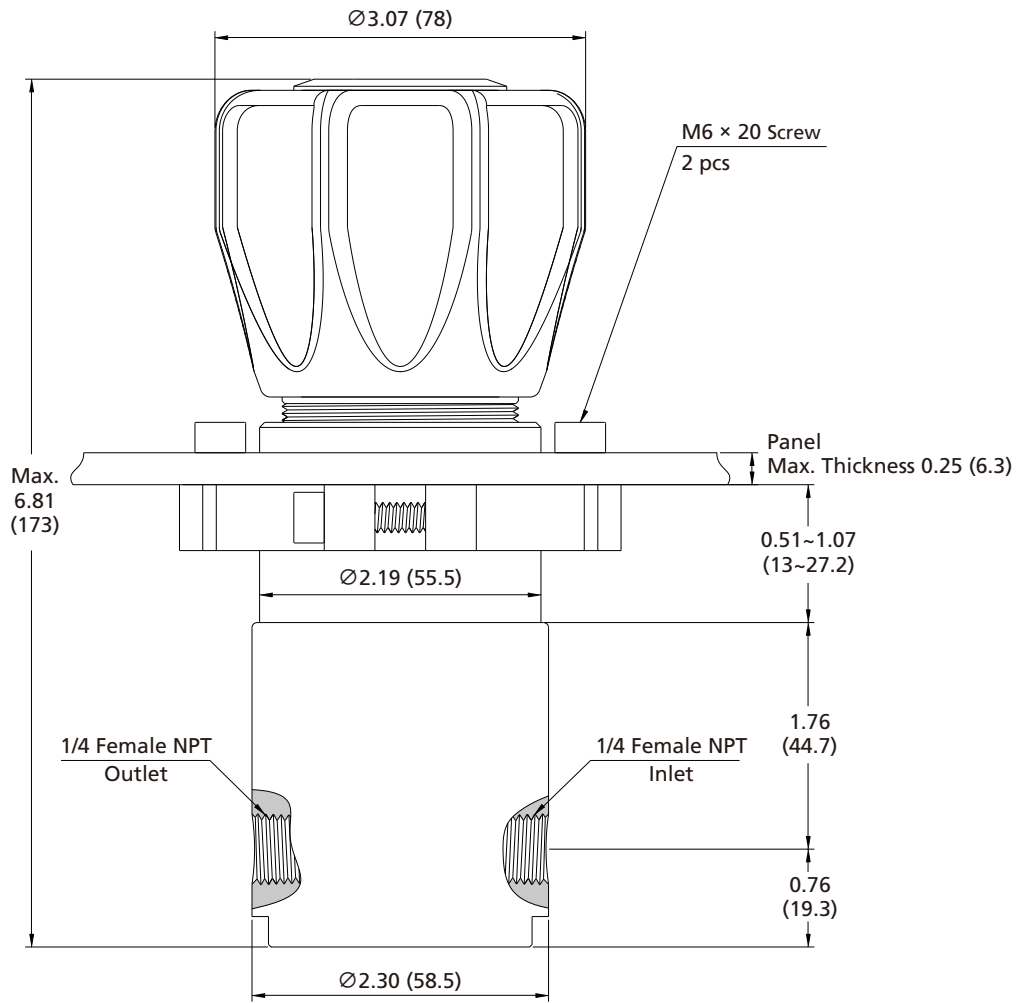

Panel Mounting Cut-Out

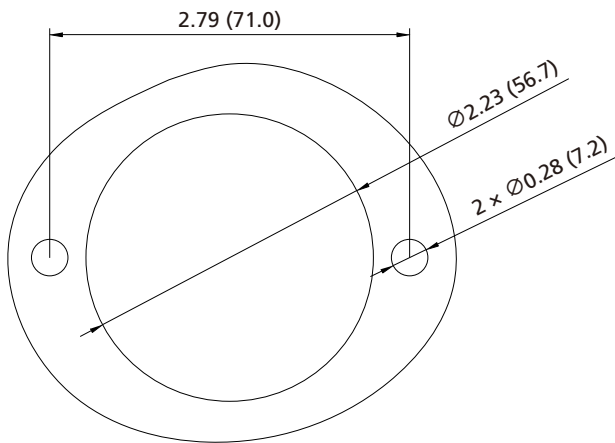

Bottom View

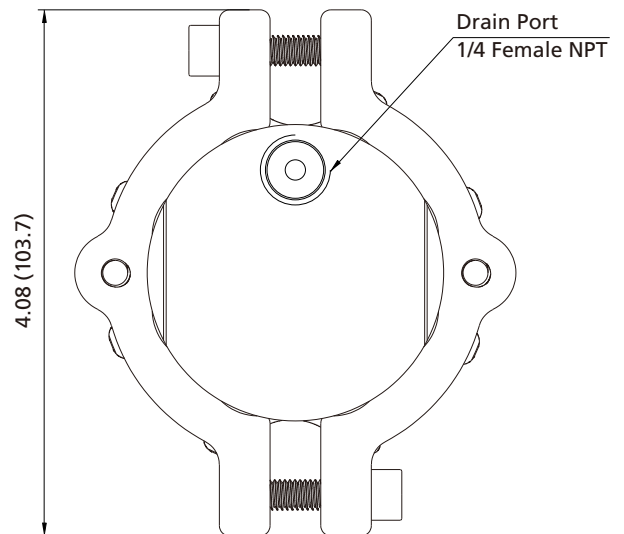

Ordering Number Description

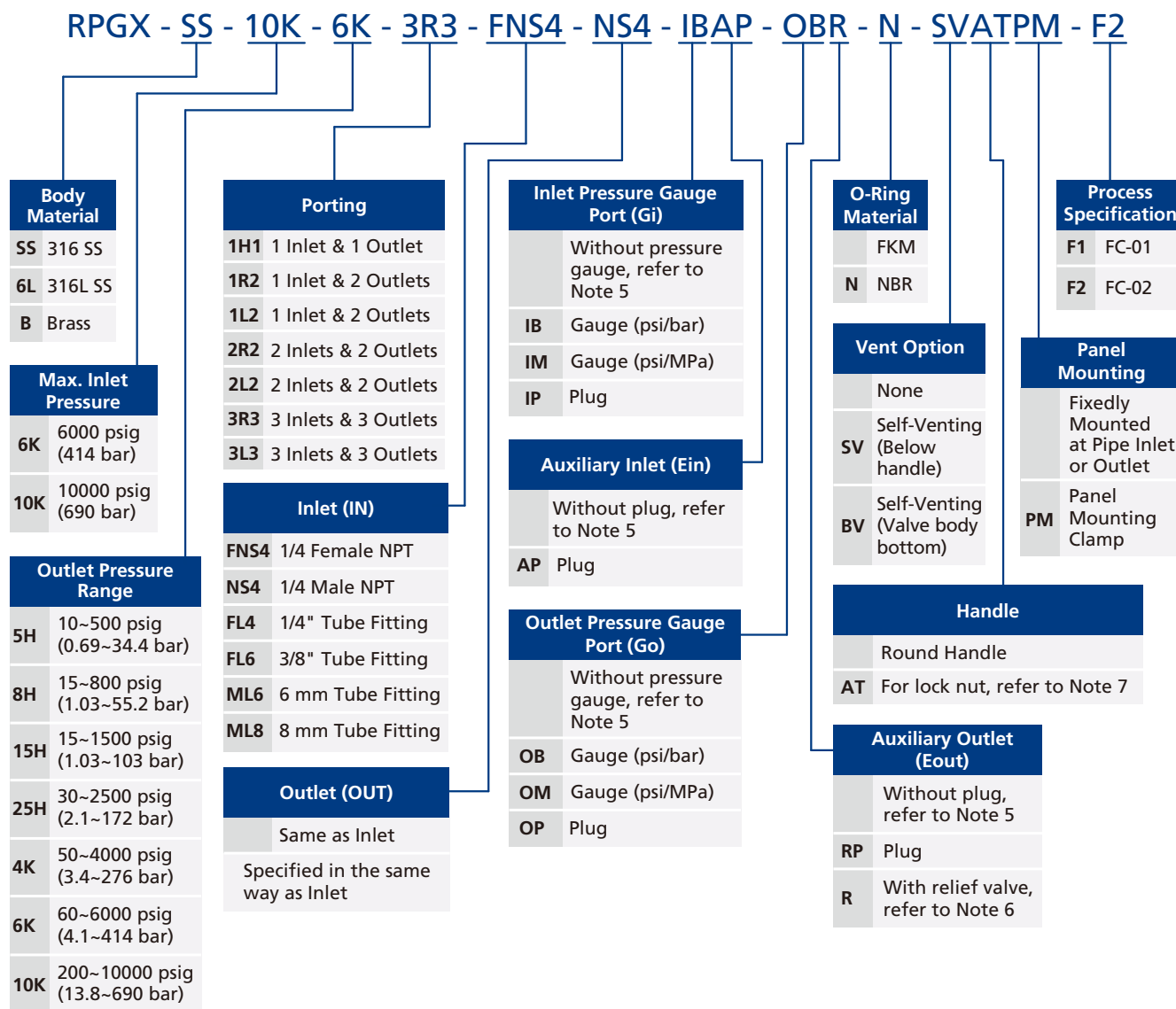

Notes:

- "Ordering Number Description" is a reference to understand the combination rules of FITOK product part number. Not all combinations are available.
- Drain port at the bottom of the regulator can not be blocked.
- Differentiating media status when selecting the vent option:
 - Non-toxic, non-hazardous gases: The SV self-venting option is recommended. In this configuration, the media is vented directly to the atmosphere from below the handle during the self-venting process.
 - Toxic or hazardous gases or liquids: The BV self-venting option is recommended. In this configuration, the media is discharged through the drain port at the bottom of the valve body during the self-venting process, allowing tubing to be installed to route the discharged media to a designated location.
- When choosing NPT or Metric/Fractional Tube Fitting ports, the regulator body comes with 1/4 Female NPT inlet and outlet by default. Other options are adapted from 1/4 Male NPT.
- When choosing NPT or Metric/Fractional Tube Fitting for inlet and outlet, gauge ports (Gi, Go) and auxiliary ports (Ein, Eout) are 1/4 Female NPT.
- For the outlet relief valve, the set pressure is factory-set to 1.05-1.1 times the maximum outlet pressure by default, FITOK can preset the specified set pressure according to customer requirements. Please specify the desired set pressure when placing your order.
- Lock nut (AT): The metal lock nut construction is designed to prevent accidental pressure adjustments. FITOK can set the specified outlet pressure based on customer requirements; simply include this information in the remarks when placing an order. If the outlet pressure is not specified, customers will need to adjust and fix it themselves.